

# NP-6118 Series user manual

1.0

2022-10-25



Automation PC

**Distribution list:**

| Name/ Group | Company |
|-------------|---------|
| EA          | CCEST   |

**Reviews/Approvals:**

|                     | Name / Function / Company | Signature |
|---------------------|---------------------------|-----------|
| <b>Author:</b>      | EA                        |           |
| <b>Reviewed by:</b> |                           |           |
|                     |                           |           |

**History:**

| Version | Date       | Author | Description    |
|---------|------------|--------|----------------|
| 1.0.0   | 2022-10-26 | EA     | First release. |
|         |            |        |                |
|         |            |        |                |
|         |            |        |                |
|         |            |        |                |
|         |            |        |                |
|         |            |        |                |
|         |            |        |                |
|         |            |        |                |
|         |            |        |                |

**Table of Contents:**

|  |    |
|--|----|
| 1. Introduction .....                          | 4  |
| 1.1 Related Manuals .....                      | 5  |
| 1.1 Safety Information .....                   | 5  |
| 1.2 Production Description .....               | 5  |
| 2. Product Introduction .....                  | 6  |
| 2.1 NP-6118 .....                              | 7  |
| 2.1.1 Features .....                           | 7  |
| 2.1.2 Product Dimension .....                  | 7  |
| 2.1.3 Product Specifications .....             | 7  |
| 2.1.4 Description of Interfaces .....          | 9  |
| 2.1.4.1 Power button .....                     | 9  |
| 2.1.4.2 Status Leds .....                      | 9  |
| 2.1.4.3 USB .....                              | 9  |
| 2.1.4.3.1 USB on the front .....               | 9  |
| 2.1.4.3.2 USB2.0 on board .....                | 10 |
| 2.1.4.4 Display ports .....                    | 11 |
| 2.1.4.4.1 DP .....                             | 11 |
| 2.1.4.4.2 HDMI .....                           | 11 |
| 2.1.4.5 Ethernet .....                         | 11 |
| 2.1.4.6 Power .....                            | 12 |
| 2.1.4.7 Serial port and Can port .....         | 13 |
| 2.1.4.8 DO .....                               | 13 |
| 2.1.4.8.1 DI .....                             | 14 |
| 3. System Setup .....                          | 16 |
| 3.1 Hardware Setup .....                       | 17 |
| 3.1.1 Attaching wall-mounted part .....        | 17 |
| 3.1.2 Attaching DIN-Rail mounted part .....    | 17 |
| 3.1.3 SSD Setup .....                          | 18 |
| 3.1.4 USB dongle Setup .....                   | 19 |
| 3.2 Driver Setup .....                         | 20 |
| 4. Safety and Maintenance .....                | 21 |
| 4.1 Safety Precautions .....                   | 22 |
| 4.1.1 General Safety Precautions .....         | 22 |
| 4.1.2 ESD Precautions .....                    | 22 |
| 4.1.3 Product Disposal .....                   | 22 |
| 4.2 Maintenance and Cleaning Precautions ..... | 22 |
| 4.2.1 Maintenance and Cleaning .....           | 23 |
| 4.2.2 Cleaning Tools .....                     | 23 |
| 5. Q&A .....                                   | 24 |
| 5.1 Digital IO electrical wiring diagram ..... | 25 |
| 5.1.1 DI electrical wiring diagram .....       | 25 |
| 5.1.2 DO electrical wiring diagram .....       | 25 |
| 5.2 How to test the DO using multimeter .....  | 25 |
| 5.3 Technical Support and Services .....       | 25 |

# 1. Introduction

This chapter provides necessary information of the product such as the features and manuals before actual use.



### 1.1 Related Manuals

The manuals related to the product are listed below, please read them as necessary along with this document before actual use.

| Name            | Purpose                                    | Contents                                     | How to get                   |
|-----------------|--|--|------------------------------|
| User manual     | Must read when operating the product.      | Describes the hardware features and settings | Download from Nodka website. |
| SDK user manual | Must read when developing the IO functions | Describes the API functions and useage       | Download from Nodka website. |

### 1.1 Safety Information

This document provides safety information using the following symbols to prevent accidents resulting in injury or death and the destruction of equipment and resources. Understand the meanings of these symbols to operate the equipment safely.

| Symbol  | Description   |
|---|---|
|    | <b>WARNING</b><br>WARNING indicates a potentially hazardous situation which, if not avoided, could result in death or serious injury. |
|   | <b>DANGER</b><br>DANGER indicates an imminently hazardous situation which, if not avoided, will result in death or serious injury.    |
|  | <b>NOTE</b><br>NOTE provide the reader with additional information or refer to detailed sources of information.                       |

### 1.2 Production Description

NP-6118 and its series products are low-power, fanless, book style exquisite embedded PC in Nodka Automation PC family. The system is designed following Nodka's COMLAC modular concept, which makes the system to be more cost-effective and easily updated. Fanless and no cable design and enclosed chassis ensure the product stability. To be more, all of the ports are designed in the front side, which will be very easy to do wiring and maintenance.

NP-6118 is an excellent performance/price ratio platform and has been widely used in the fields of motion control, smart gateway, instrument collection terminal and automation control.

## 2. Product Introduction

This chapter describes product component and their functions, pin assignment of each connector in detail.

**2.1 NP-6118**

NP-6118 is basic module in its series and provides various kind of interfaces based on Intel Celeron J6412 processor, which has been widely used in the fields of motion control, smart gateway, instrument collection terminal and automation control.

**2.1.1 Features**

- ◆ 1 x Intel I211-AT GbE controller
- ◆ 2 x RTL8111H GbE controller
- ◆ 4 x USB Type A ports and 1 x Type A on board for dongle installation
- ◆ 1 x RS232 , 2 x RS485 , RS485 support auto flow control
- ◆ 2 x CAN2.0 Bus
- ◆ 16 x isolated DI, 16 x isolated DO
- ◆ 1 x miniPCIe expansion slot
- ◆ 1 x M.2 slot for Wifi
- ◆ Support Wall-mounted or DIN-Rail mounted
- ◆ Support -20 ~ 60°C wide temperature environment

**2.1.2 Product Dimension**

Unit: mm

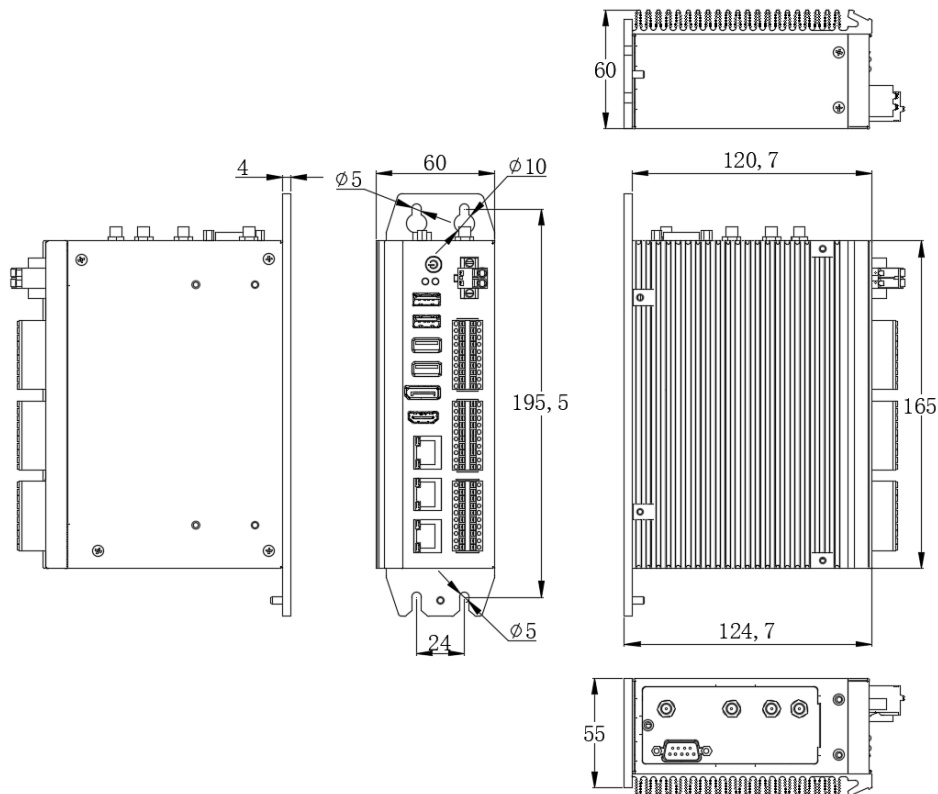

Figure 1 Dimension of NP-6118

**2.1.3 Product Specifications**

| Module |     | NP-6118-16I160C-J6412   |
|--------|-----|---|
| System | CPU | Intel® Celeron J6412, 2.0~2.6GHz, 4 cores/4 threads, 1.5MB L2 cache |
|        | TDP | 10W   |



|             |                           |   |   |
|-------------|---------------------------|---|---|
|             | BIOS                      | AMI UEFI 64Mbit   |   |
|             | Memory                    | 1 x SO-DIMM DDR4-2400MHz (Max. 16GB)  |   |
|             | Storage                   | 1 x mSATA slot  |   |
|             | USB                       |   | 2 x USB3.0, 2 x USB2.0                    |
|             |                           |   | 1 x USB2.0 on board                       |
|             | COM                       | 1 x RS232, 2 x RS485  |   |
|             | Ethernet                  |   | 1 x Intel I211-AT GbE LAN controller      |
|             |                           |   | 2 x RTL8111H GbE LAN controller           |
|             | DI                        | 16 x DI NPN/PNP, isolated voltage:2500Vrms  |   |
|             | DO                        | 16 x DO, Transistor output I <sub>max</sub> :500mA, isolated voltage: 2500Vrms                      |   |
|             | CAN                       | 2 x CAN Bus 2.0A/B  |   |
|             | HDMI                      | Support up to 4096 x 2160   |   |
|             | DP                        | Support up to 4096 x 2160   |   |
|             | Expansion                 |   | 1 x full-size miniPCIe slot with SIM slot |
|             |                           | 1 x M.2 KEY-A for Wifi  |   |
| Watchdog    | 1~255 levels programmable |   |   |
| OS          | Microsoft Windows         | Windows 10 IoT  |   |
|             | Linux                     | Ubuntu  |   |
| Power       | Voltage Input             | DC12~24V ±10%, overcurrent, overvoltage and polarity inverse protection, (internal UPS is optional) |   |
|             | Power Consumption         | Max. 45W  |   |
| Chassis     | Structure                 | Fanless, support Wall-mounted or DIN-Rail mounted   |   |
|             | Dimensions                | (L)165mm x (W)124.7mm x (H)60mm   |   |
|             | Net Weight                | 2.1Kg   |   |
| Environment | <b>Work Temperature</b>   | <b>-20°C ~ 60°C (-4°F ~ 140°F) with air flow (SSD)</b>  |   |
|             | Storage Temperature       | -40°C ~ 80°C (-40°F ~ 176°F) with air flow (SSD)  |   |
|             | Relative Humidity         | 5~95% (Non-condensing)  |   |
|             | Operating Vibration       | 5~500Hz, 1.5Grms@with SSD, Follow IEC60068-2-64   |   |
|             | Operating Shock           | 20G peak acceleration(11ms duration) with SSD, Follow IEC60068-2-27                                 |   |
|             | EMC                       | CE/FCC Class A  |   |

**2.1.4 Description of Interfaces**

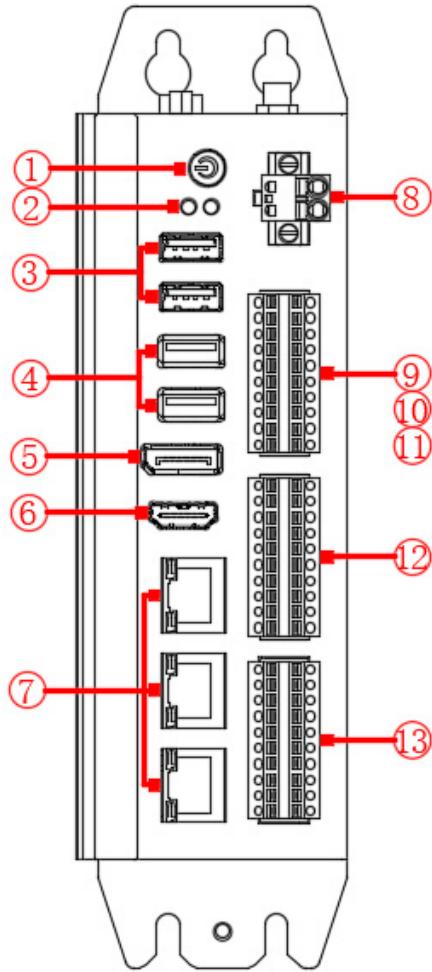

| No. | Name         |
|-----|--------------|
| 1   | Power button |
| 2   | Status Leds  |
| 3   | USB2.0       |
| 4   | USB3.0       |
| 5   | DP           |
| 6   | HDMI         |
| 7   | Ethernet     |
| 8   | DC_IN        |
| 9   | CAN          |
| 10  | RS232        |
| 11  | RS485        |
| 12  | DO           |
| 13  | DI           |

Figure 2 Interfaces of NP-6118

**2.1.4.1 Power button**

The product provides a power button with power led on the front, which can be used to turn on or turn off the PC in the case of power supply is connected.

**2.1.4.2 Status Leds**

The product provides two status leds on the front to indicate the status of the power and the storage disk operation.

| LED       | Status        | Description                    |
|-----------|---------------|--------------------------------|
| Power Led | off           | The product is power on        |
|           | on(Green)     | The product is power off       |
| Disk Led  | blink(Orange) | The disk is reading or writing |

**2.1.4.3 USB**

The product provide four USB TYPE-A ports on the front and one USB TYPE-A port on the board can be used to install the USB dongle.

**2.1.4.3.1 USB on the front**

NP-6118 provide two USB3.0 ports and two USB2.0 ports on the front when using Intel Celeron J6412 processor.

Pin definition of USB3.0 port:

| Pin No. | Signals |
|---------|---------|
| 1       | VCC5    |
| 2       | DATA-   |
| 3       | DATA+   |
| 4       | GND     |
| 5       | SSRX-   |
| 6       | SSRX+   |
| 7       | GND     |
| 8       | SSTX-   |
| 9       | SSTX+   |

Pin definition of USB2.0 port:

| Pin No. | Signals |
|---------|---------|
| 1       | VCC5    |
| 2       | DATA-   |
| 3       | DATA+   |
| 4       | GND     |

### 2.1.4.3.2 USB2.0 on board

The product provides a USB2.0 on board which can be used for USB dongle. It can be seen after four screws in the aluminum radiator are unscrewed. Please refer to the blue area in the below figure.

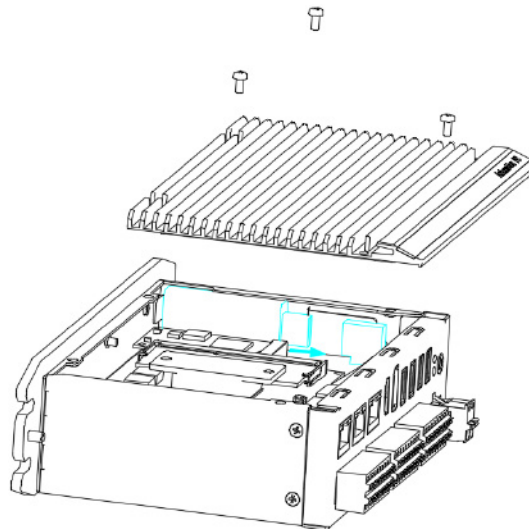

Figure 3 USB2.0 on board

Pin definition of USB2.0 port on board:

| Pin No. | Signals |
|---------|---------|
| 1       | VCC5    |
| 2       | DATA-   |
| 3       | DATA+   |
| 4       | GND     |

**2.1.4.4 Display ports**

The product supports both DP and HDMI HD display ports.

**2.1.4.4.1 DP**

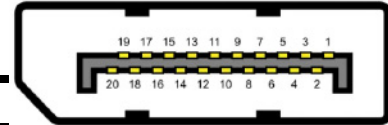

Pin definition of DP connector:

| DP Connector |               |         |              |
|--------------|---------------|---------|--------------|
| Pin No.      | Signals       | Pin No. | Signals      |
| 1            | ML_Lane 0(p)  | 2       | GND          |
| 3            | ML_Lane 0(n)  | 4       | ML Lane 1(p) |
| 5            | GND           | 6       | ML Lane 1(n) |
| 7            | ML_Lane 2(p)  | 8       | GND          |
| 9            | ML_Lane 2(n)  | 10      | ML_Lane 3(p) |
| 11           | GND           | 12      | ML_Lane 3(n) |
| 13           | GND           | 14      | GND          |
| 15           | AUX_CH(p)     | 16      | GND          |
| 17           | AUX_CH(n)     | 18      | Hot Plug     |
| 19           | DP_PWR_Return | 20      | Power        |

**2.1.4.4.2 HDMI**

Pin definition of HDMI connector:

| HDMI TYPE-A Connector |                    |         |                   |
|-----------------------|--------------------|---------|-------------------|
| Pin No.               | Signals            | Pin No. | Signals           |
| 1                     | TMDS DATA 2+       | 11      | TMDS CLOCK SHIELD |
| 2                     | TMDS DATA 2 SHIELD | 12      | TMDS CLOCK-       |
| 3                     | TMDS DATA 2-       | 13      | CEC               |
| 4                     | TMDS DATA 1+       | 14      | N.C.              |
| 5                     | TMDS DATA 1 SHIELD | 15      | DDC CLOCK         |
| 6                     | TMDS DATA 1-       | 16      | DDC DATA          |
| 7                     | TMDS DATA 0+       | 17      | GND               |
| 8                     | TMDS DATA 0 SHIELD | 18      | +5V PWR           |
| 9                     | TMDS DATA 0-       | 19      | HOT PLUG DETECT   |
| 10                    | TMDS CLOCK+        |         |                   |

**2.1.4.5 Ethernet**

The product provides three GbE Lan controllers using standard RJ45 connectors, they are LAN1, LAN2 and LAN3.

Pin definition of RJ45 connector:

| Pin No. | Signals    |            |
|---------|------------|------------|
|         | 100BASE-TX | 1000BASE-T |
| 1       | TX+        | TRD+(0)    |
| 2       | TX-        | TRD-(0)    |
| 3       | RX+        | TRD+(1)    |
| 4       | N.C.       | TRD+(2)    |
| 5       | N.C.       | TRD-(2)    |

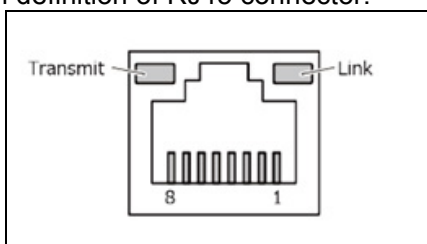

|  |   |      |         |
|--|---|------|---------|
|  | 6 | RX-  | TRD-(1) |
|  | 7 | N.C. | TRD+(3) |
|  | 8 | N.C. | TRD-(3) |

There are two status leds in the RJ45 connector indicate the status of the link and transmit separately. Link led is on when link successfully, and when the network is working in the 1000Mbps, the transmit led is blinking in orange color and in green color when working in the other speed.

| Items                    | Parameters                     |
|--------------------------|--------------------------------|
| Network type             | 1000BASE-T/100BASE-TX/10BASE-T |
| Transmission speed*      | 1000M/100M/10M bps             |
| Max. network path length | 100m/segment                   |

\* Operation at 1000Mbps requires a category 5e or greater cable.

#### 2.1.4.6 Power

The product support DC12V~24V wide voltage input.

Pin definition of DC IN connector:

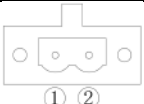
|  | Pin No. | Signal | Pin No. | Signal |
|---|---------|--------|---------|--------|
|   |         | 1      | GND     | 2      |



1. Must check whether the voltage output of the power supply matches the PC DC input before connecting to the PC.
2. Must check the positive and negative pole marks on the housing before connecting to the power.
3. Must turn off the power before inserting or removing the boards or cables.
4. PE should be well grounded when operating.
5. Must do not connect AC power supply to the PC directly.

**2.1.4.7 Serial port and Can port**

The product provides three serial ports and two CAN bus ports as the phoenix connector on the front.

Pin definition of the communication connector:

| Pin No. | Signals | Description     | Pin No. | Signals | Description          |
|---------|---------|-----------------|---------|---------|----------------------|
| 20      | C2L     | CH2_CAN_L       | 19      | C2H     | CH2_CAN_H            |
| 18      | C1L     | CH2_CAN_L       | 17      | C1H     | CH1_CAN_H            |
| 16      | CGnd    | CAN Gnd         | 15      | CGnd    | CAN Gnd              |
| 14      | RX*     | COM3 RS232_RX   | 13      | TX*     | COM3 RS232_TX        |
| 12      | A2*     | COM2 RS485_A    | 11      | B2*     | COM2 RS485_B         |
| 10      | A1*     | COM1 RS485_A    | 9       | B1*     | COM1 RS485_B         |
| 8       | Gnd     | GND             | 7       | Gnd     | GND                  |
| 6       | R_STS   | DO              | 5       | P_OK    | DI                   |
| 4       | P_STS   | Power On status | 3       | SW      | Remote switch on/off |
| 2       | SGnd    | Signal GND      | 1       | SGnd    | Signal GND           |

\*The serial port COM1, COM2 and COM3 are enumerated as '/dev/ttyS0', '/dev/ttyS1' and '/dev/ttyS2' in the Linux operating system.

**2.1.4.8 DO**

The product provides 16 Digital Output channels, transistor output,  $I_{max}: 500mA$ ,  $V_{max}: 50V$ . Please remind that a diode shall be connected in parallel for freewheeling when external inductive load is connected.

Pin definition of the DO connector:

| Pin No. | Signals | Function | Pin No. | Signals | Function |
|---------|---------|----------|---------|---------|----------|
| 20      | Y0      | DO_CH0   | 19      | Y8      | DO_CH8   |
| 18      | Y1      | DO_CH    | 17      | Y9      | DO_CH9   |
| 16      | Y2      | DO_CH2   | 15      | Y10     | DO_CH 0  |
| 14      | Y3      | DO_CH3   | 13      | Y11     | DO_CH    |
| 12      | Y4      | DO_CH4   | 11      | Y12     | DO_CH12  |
| 10      | Y5      | DO_CH5   | 9       | Y13     | DO_CH13  |
| 8       | Y6      | DO_CH6   | 7       | Y14     | DO_CH14  |
| 6       | Y7      | DO_CH7   | 5       | Y15     | DO_CH15  |
| 4       | YGnd    | DO_GND   | 3       | YGnd    | DO_GND   |
| 2       | YGnd    | DO_GND   | 1       | YGnd    | DO_GND   |

Wiring:

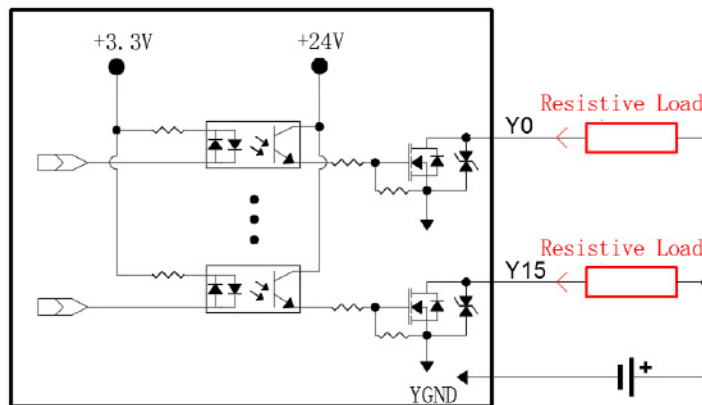

Figure 4 Wiring of resistive load

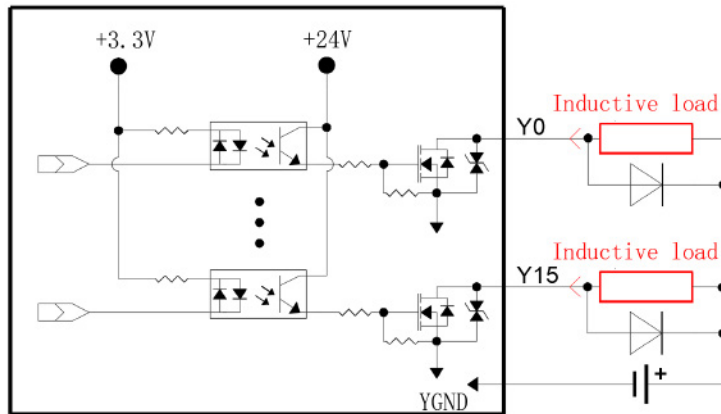

Figure 5 Wiring of inductive load



1. DO output load current is not allowed to exceed the maximum current of 500mA.
2. The maximum DO load voltage is not allowed to exceed 50VDC.
3. Must don't connect the Power positive pole to the DO pin or DO GND directly.

### 2.1.4.1 DI

The product provides 16 isolated Digital input channels, which support both NPN and PNP wiring solutions.

Pin definition of the DI connector:

| Pin No. | Signals | Function | Pin No. | Signals | Function |
|---------|---------|----------|---------|---------|----------|
| 20      | X0      | DI_CH0   | 19      | X8      | DI_CH8   |
| 18      | X1      | DI_CH    | 17      | X9      | DI_CH9   |
| 16      | X2      | DI_CH 2  | 15      | X10     | DI_CH10  |
| 14      | X3      | DI_CH 3  | 13      | X11     | DI_CH11  |
| 12      | X4      | DI_CH 4  | 11      | X12     | DI_CH12  |
| 10      | X5      | DI_CH 5  | 9       | X13     | DI_CH13  |
| 8       | X6      | DI_CH 6  | 7       | X14     | DI_CH14  |
| 6       | X7      | DI_CH 7  | 5       | X15     | DI_CH15  |
| 4       | XCom    | DI_COM   | 3       | XCom    | DI_COM   |
| 2       | XCom    | DI_COM   | 1       | XCom    | DI_COM   |

➤ NPN wiring solution

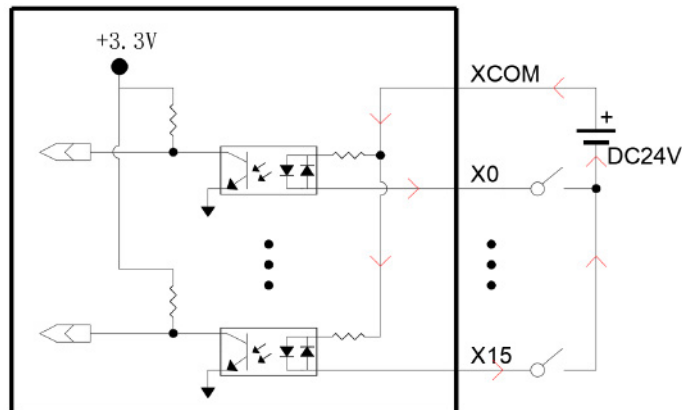

Figure 6 DI NPN wiring solution

➤ PNP wiring solution

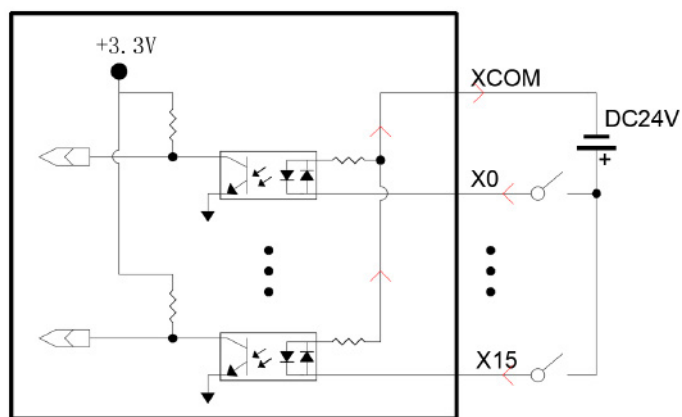

Figure 7 DI PNP wiring solution



## 3. System Setup

This chapter mainly introduces how to setup hardware components drivers.

### 3.1 Hardware Setup

#### 3.1.1 Attaching wall-mounted part

Use 4 screws on the back to attach the wall-mounted part, please refer to the below figure.

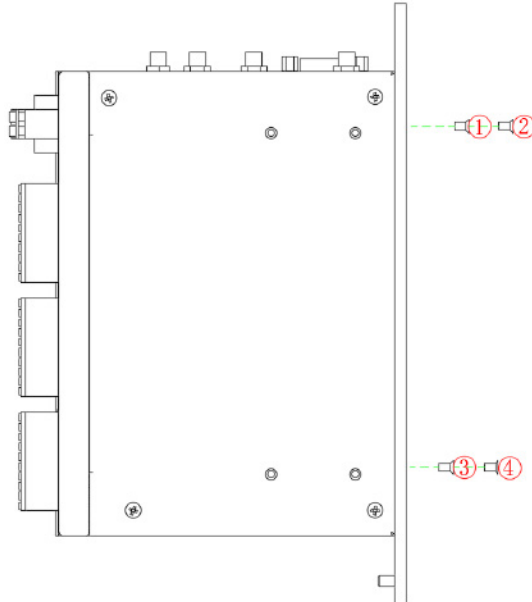

Figure 8 Attach the wall-mount part



1. Do not tighten screws with excess force.
2. Screw holes may be damaged if screws are tightened with a torque greater than the specified torque. The specified tightening torque is 5-6 kgf·cm.

#### 3.1.2 Attaching DIN-Rail mounted part

Use 4 screws on the back to attach the DIN-Rail mounted part, please refer to the below figure.

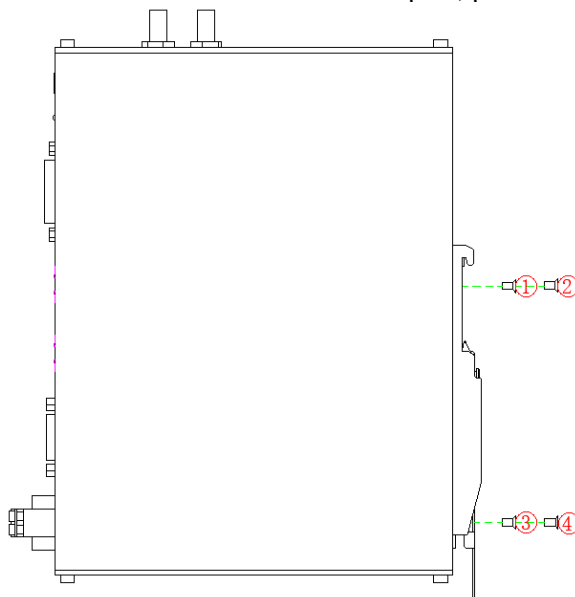

Figure 9 Attach DIN-Rail mounted part



1. Do not tighten screws with excess force.
2. Screw holes may be damaged if screws are tightened with a torque greater than the specified torque. The specified tightening torque is 5-6 kgf-cm.

### 3.1.3 SSD Setup

1. Unscrew four screws(①~④) in the aluminum radiator.
2. Remove the aluminum radiator(⑤), please be care of the thermal grease not to be damaged.
3. Then you can install or uninstall the SSD(⑥).

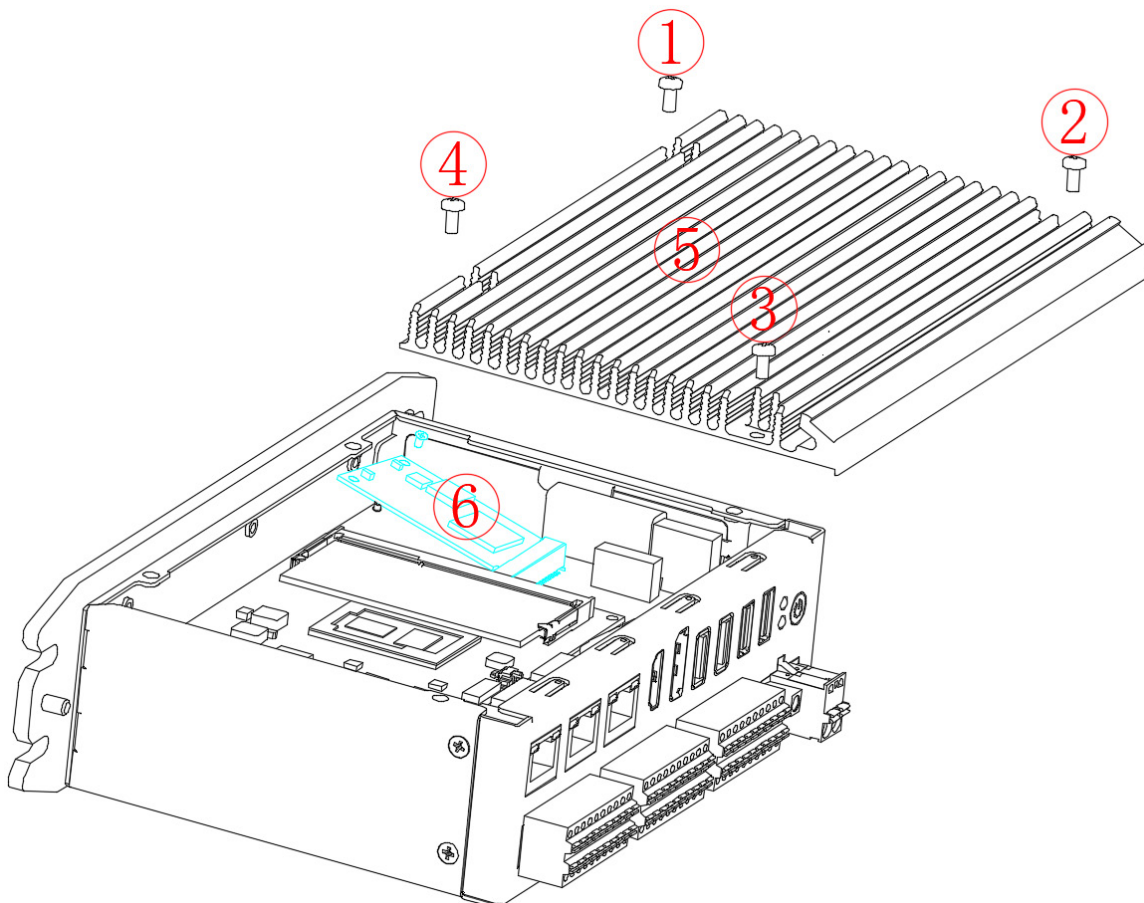

Figure 10 SSD Setup



1. Must disconnect the power supply before operating.
2. Pay attention to electrostatic discharge.
3. Do not tighten screws with excess force.

### 3.1.4 USB dongle Setup

1. Unscrew four screws(①~④) in the aluminum radiator.
2. Remove the aluminum radiator(⑤), please be care of the thermal grease not to be damaged.
3. Then you can install or uninstall the USB device(⑦).

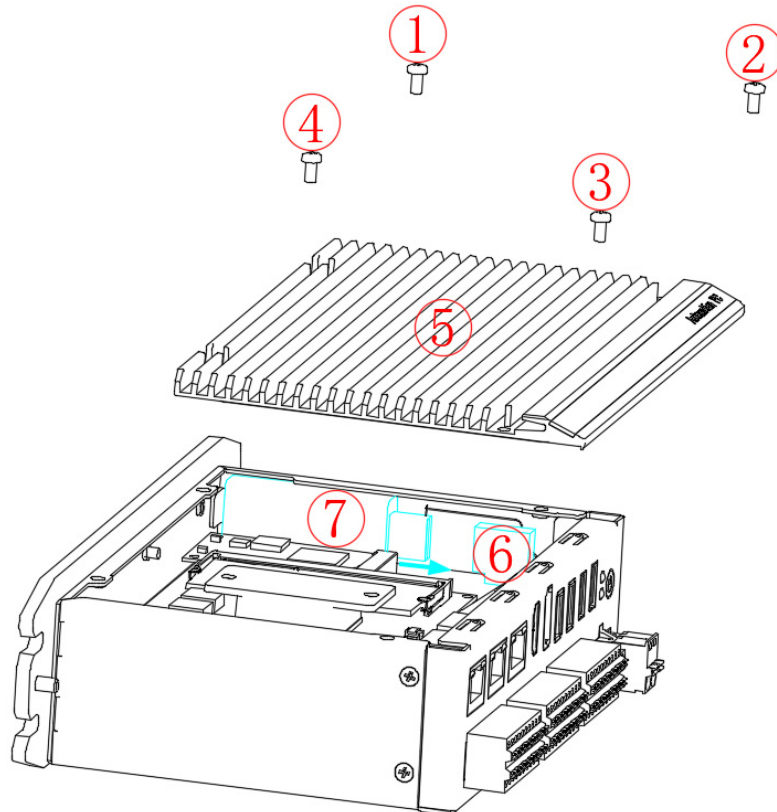

Figure 11 USB dongle Setup

### **3.2 Driver Setup**

1. Download the driver install files from Nodka website or ask for support from your retailer.
2. Install the driver software according to the installation wizard.

## **4. Safety and Maintenance**

Please follow the precautions described in this chapter, otherwise may cause device damaged.

## 4.1 Safety Precautions

Please follow the safety precautions described in this section below.

### 4.1.1 General Safety Precautions

Please ensure that the following safety precautions are followed:

- Follow electrostatic precautions if you open the device;
- When installing, moving or modifying the device, ensure that the power is switched off and the power cable is disconnected;
- It is forbidden to use more than the specified voltage as this may cause a fire or electric shock;
- Electric shock may occur if the device chassis is opened while the device is running;
- Do not drop or insert any debris into the device vents;
- If large quantities of dust, water or liquid enter the device, disconnect the power supply and contact the supplier;
- The following are prohibited:
  - It is forbidden to drop the device on a hard surface;
  - It is forbidden to knock or apply excessive force to the device;
  - It is forbidden to use the device in places where the rated environment exceeds the standard.

### 4.1.2 ESD Precautions

Failure to take ESD precautions during device installation may result in damage to the device or injury to the user. Electrostatic discharge (ESD) can cause damage to the components of a device. Dry climates are more prone to ESD. Therefore, the following anti-static precautions need to be strictly followed when opening the equipment:

- Wearing anti-static bracelet;
- Personally well grounded: When handling electronic components, grounded conductive substances should be touched frequently;
- Using anti-static mats: Electronic components should be operated on anti-static mats, which can reduce the possibility of ESD damage.
- Touch only the edges of electronic components: operate by holding the edge of electronic components.

### 4.1.3 Product Disposal

Disposal of used batteries must be in accordance with local environmental regulations.

- Outside the European Union:

If you want to dispose the used electrical and electronic products outside the European Union, please contact your local authority so as to comply with the correct disposal method.

- Within the European Union:

EU-wide legislation, as implemented in each Member State, requires that waste electrical and electronic products carrying the mark (right) must be disposed of separately from normal household waste. This includes monitors and electrical accessories, such as signal cables or power cords. When you need to dispose of your display products, please follow the guidance of your local authority, or ask the shop where you purchased the product. The mark on electrical and electronic products only applies to the current European Union Member States. Please follow the national guidelines for electrical and electronic product disposal.



## 4.2 Maintenance and Cleaning Precautions

Please follow the guidelines below when maintaining or cleaning the product.

#### 4.2.1 Maintenance and Cleaning

Prior to cleaning any part or component of the product, please read the details below:

Never spray or squirt liquids directly onto any other components.

- The interior does not require cleaning. Keep fluids away from the interior.
- Be careful not to damage the small, removable components inside.
- Turn off before cleaning.
- Never drop any objects or liquids through the openings.
- Be cautious of any possible allergic reactions to solvents or chemicals used when cleaning.
- Avoid eating, drinking and smoking nearby.
- Fans are regularly cleaned of dust.

#### 4.2.2 Cleaning Tools

Some components may only be cleaned using special tool for the safety. In such case, the product will be explicitly mentioned in the cleaning tips.

Below is a list of items to be used for cleaning.

- **Cloth** – Although paper towels or tissues can be used, a soft, clean piece of cloth is recommended.
- **Water or rubbing alcohol** – A cloth moistened with water or rubbing alcohol should be used;
- **Using solvents** – The use of solvents is not recommended as they may damage the plastic parts.
- **Vacuum cleaner** – Using a vacuum specifically designed for computers is one of the best methods of cleaning. Dust and dirt can restrict the airflow and cause circuitry to corrode.
- **Cotton swabs** - Cotton swabs moistened with rubbing alcohol or water are excellent tools for wiping hard to reach areas.
- **Foam swabs** - Whenever possible, it is best to use lint free swabs such as foam swabs for cleaning.



## 5. Q&A

This section explains and illustrates common problems that users may encounter when using the product.

### 5.1 Digital IO electrical wiring diagram

The below sections can be referred to by the field electrical engineer.

#### 5.1.1 DI electrical wiring diagram

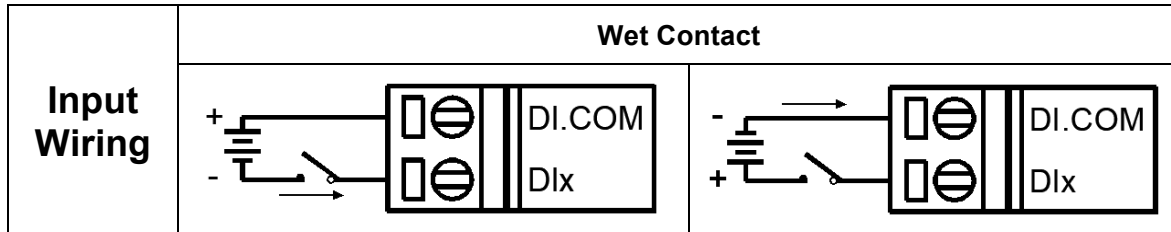

Figure 12 DI electrical wiring diagram

#### 5.1.2 DO electrical wiring diagram

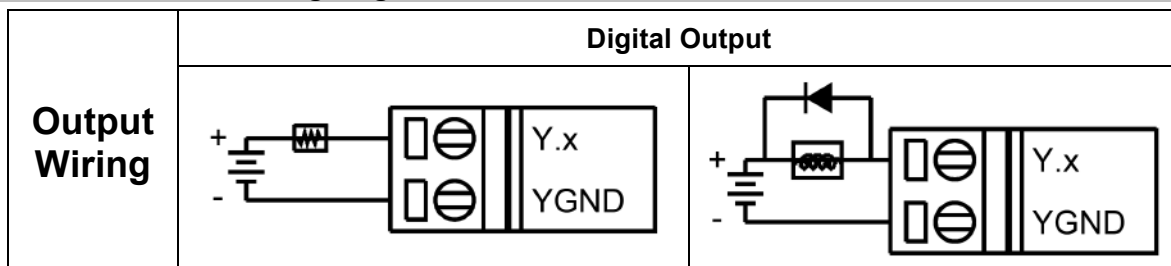

Figure 13 DO electrical wiring diagram

### 5.2 How to test the DO using multimeter

When DO works as OC gate output, its internal equivalent is a triode circuit controlled by the base. You can adjust the multimeter to the buzzer position, with the red probe connected to DOx and the black probe connected to DOGND. Then turn on the DOx in the application, and the multimeter buzzer will be on if the DO is on, otherwise multimeter buzzer will not be on.

### 5.3 Technical Support and Services

For documentation and related drivers, please contact your local distributors for support and service.